



US008499709B2

(12) **United States Patent**
Lee et al.

(10) **Patent No.:** **US 8,499,709 B2**
(45) **Date of Patent:** **Aug. 6, 2013**

(54) **MOORING SYSTEM FOR A VESSEL**

(56) **References Cited**

(75) Inventors: **Phill-Seung Lee**, Daejeon (KR);
SoonHung Han, Daejeon (KR); **Hyun Chung**,
Daejeon (KR); **Yong-Yook Kim**, Daejeon (KR);
Kook-Jin Choi, Daejeon (KR); **Sang-Il Kim**,
Daejeon (KR); **Young-Hee Cho**, Daejeon (KR);
Young-Su Kim, Daejeon (KR)

U.S. PATENT DOCUMENTS
6,715,977 B2 * 4/2004 Dobner et al. 414/141.3
6,910,435 B2 * 6/2005 Hadcroft et al. 114/230.15
6,938,570 B2 * 9/2005 Montgomery et al. 114/230.1
7,293,519 B2 * 11/2007 Montgomery et al. 114/230.1
8,215,256 B2 * 7/2012 Montgomery et al. 114/230.1

(73) Assignee: **Korea Advanced Institute of Science and Technology**, Daejeon (KR)

FOREIGN PATENT DOCUMENTS
JP S50-068166 6/1975
JP H07-010074 1/1995
JP H07-033075 2/1995
JP 2006-232046 9/2006
JP 2008-195114 8/2008
KR 10-2006-0009809 2/2006

(*) Notice: Subject to any disclaimer, the term of this patent is extended or adjusted under 35 U.S.C. 154(b) by 315 days.

OTHER PUBLICATIONS

The International Search Report dated Dec. 20, 2011 and Written Opinion.

(21) Appl. No.: **12/969,994**

* cited by examiner

(22) Filed: **Dec. 16, 2010**

Primary Examiner — Daniel Venne

(65) **Prior Publication Data**

(74) *Attorney, Agent, or Firm* — Bacon & Thomas, PLLC

US 2012/0114422 A1 May 10, 2012

(30) **Foreign Application Priority Data**

(57) **ABSTRACT**

Nov. 4, 2010 (KR) 10-2010-0109349

A mooring system for a vessel includes an attachment unit configured to be detachably attached to a hull of the vessel; a robot arm including a plurality of arms, the arms being coupled to each other to turn in a vertical direction, the robot arm extending by an arm actuator provided thereto to transfer the attachment unit to an attachment position of the hull; a rotation unit connected to the robot arm and allowing the robot arm to turn in a horizontal direction; and a mooring winch for winding a mooring cable to draw the attachment unit. A floating body or a quay wall may include the mooring system.

(51) **Int. Cl.**
E02B 3/24 (2006.01)

(52) **U.S. Cl.**
USPC **114/230.19**

(58) **Field of Classification Search**
USPC 114/230.1, 230.15, 230.17, 230.18,
114/230.19

See application file for complete search history.

14 Claims, 9 Drawing Sheets

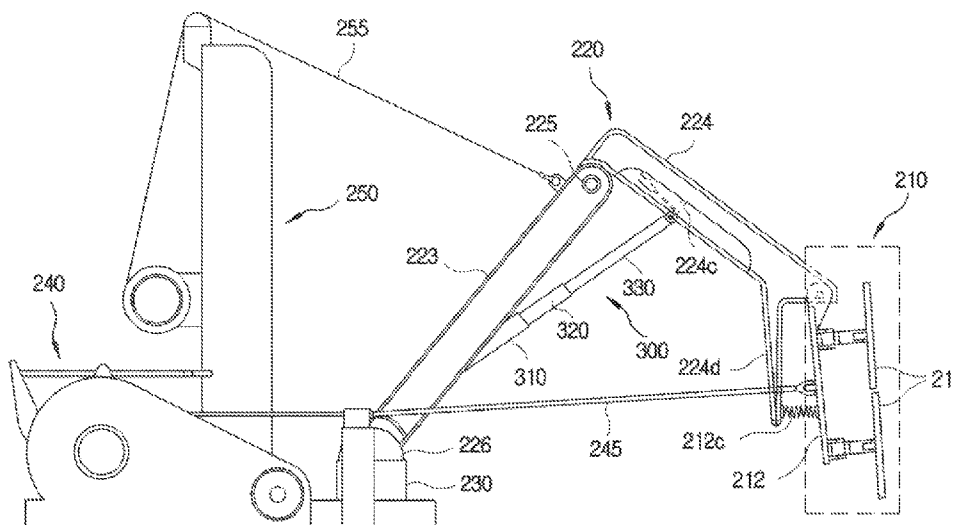

FIG. 1A
(PRIOR ART)

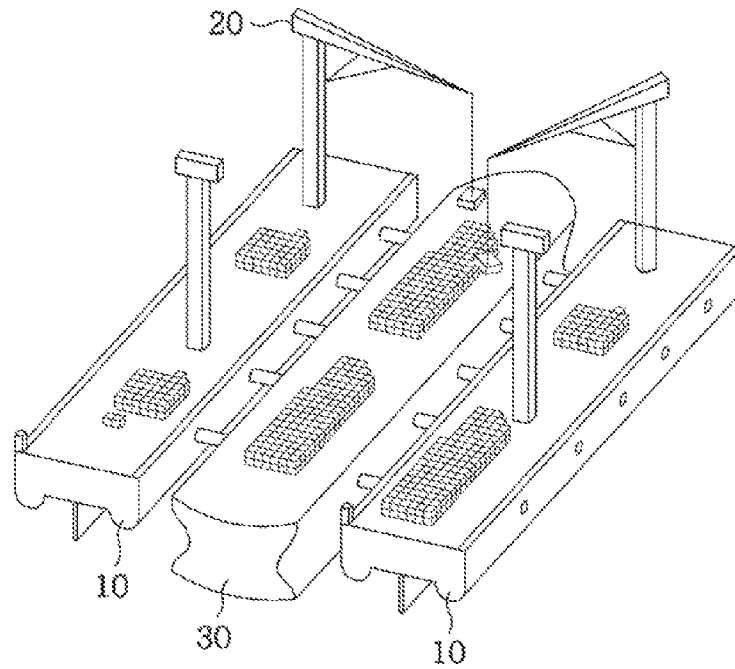

FIG. 1B
(PRIOR ART)

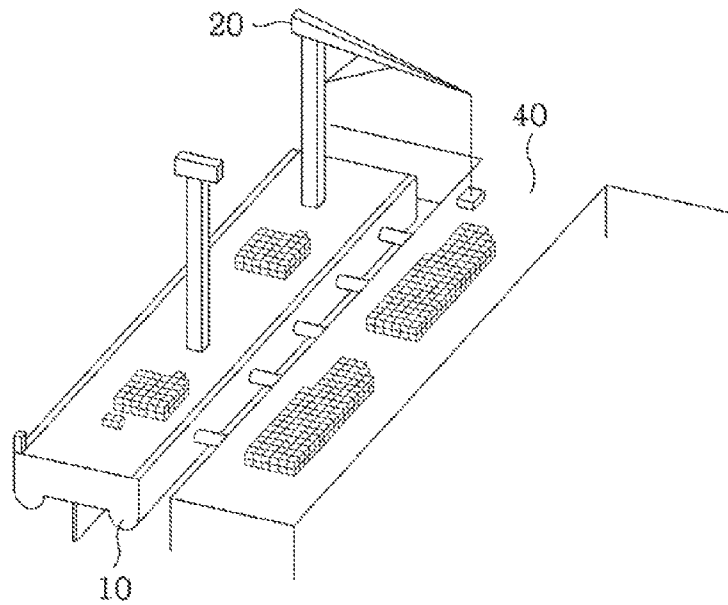

FIG. 2A

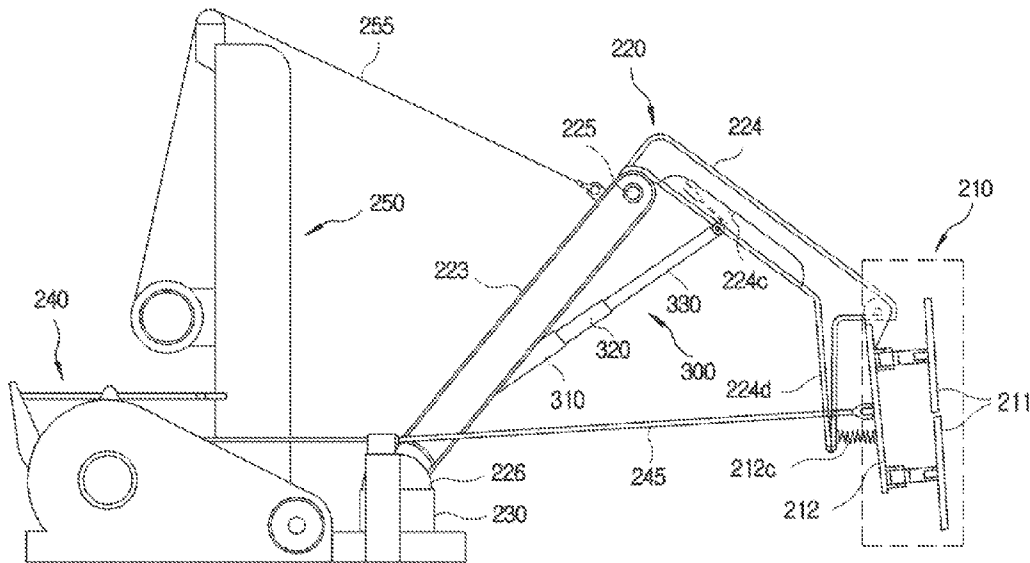

FIG. 2B

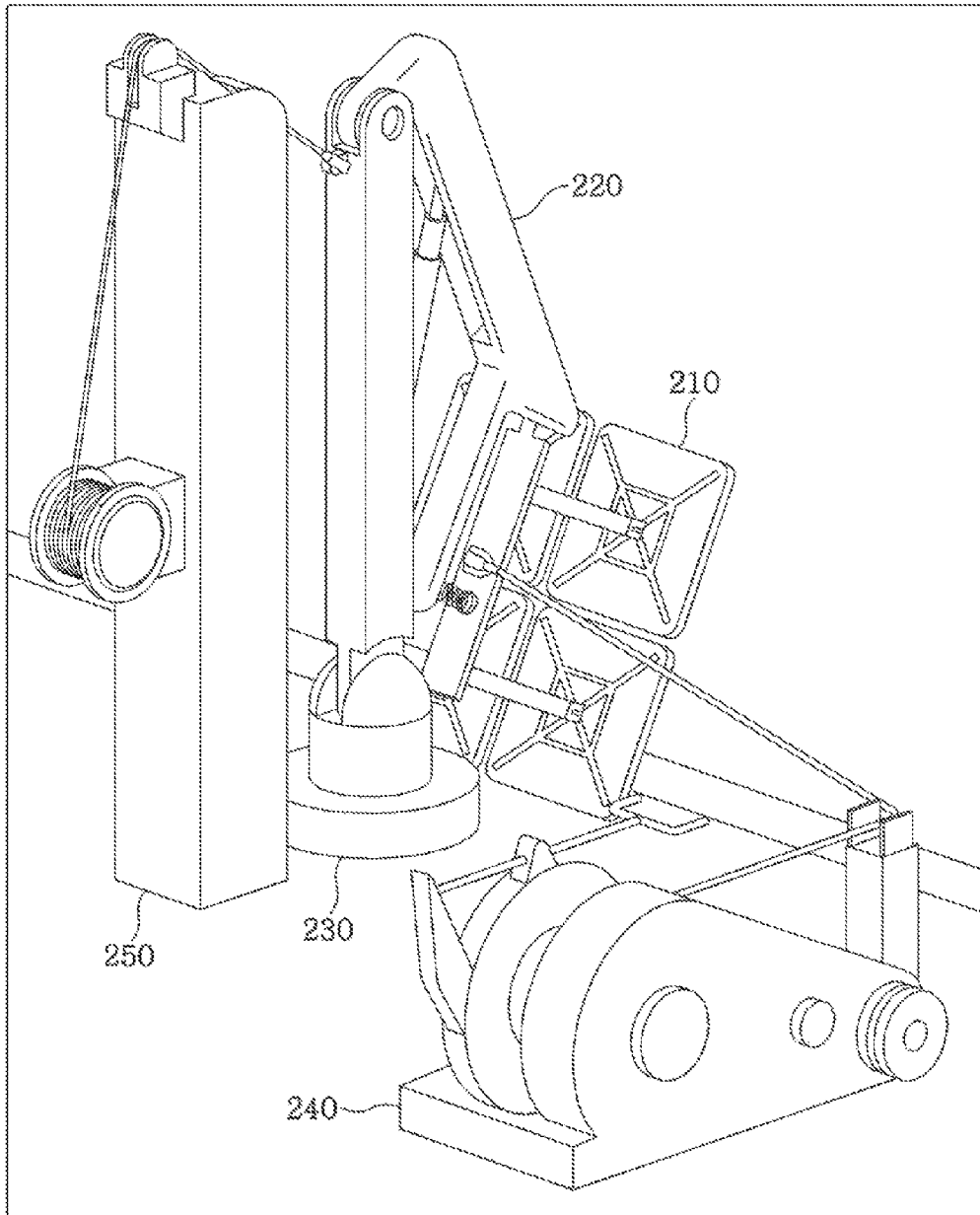

FIG. 3A

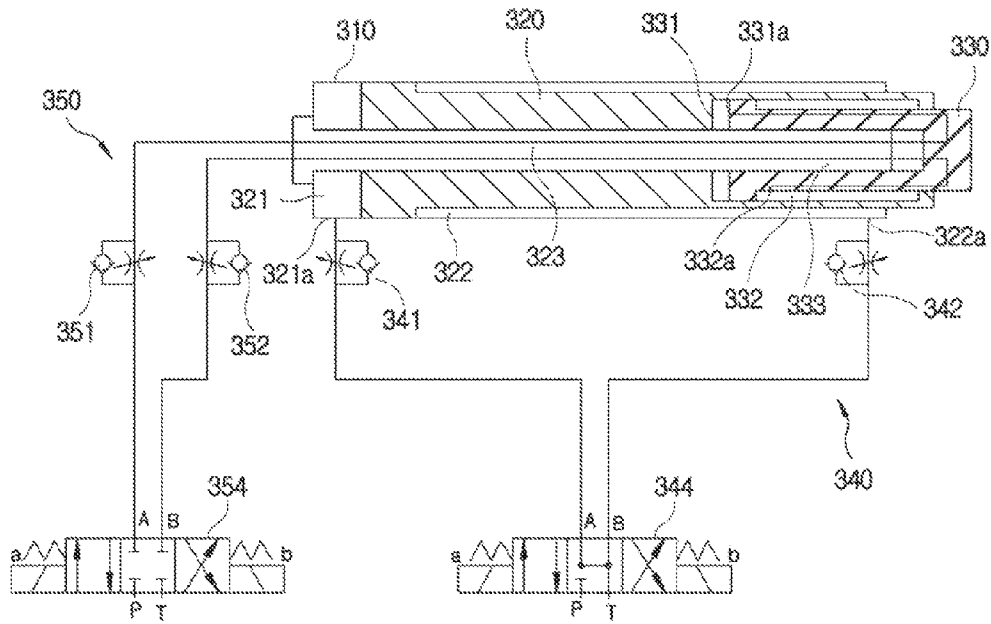

FIG. 3B

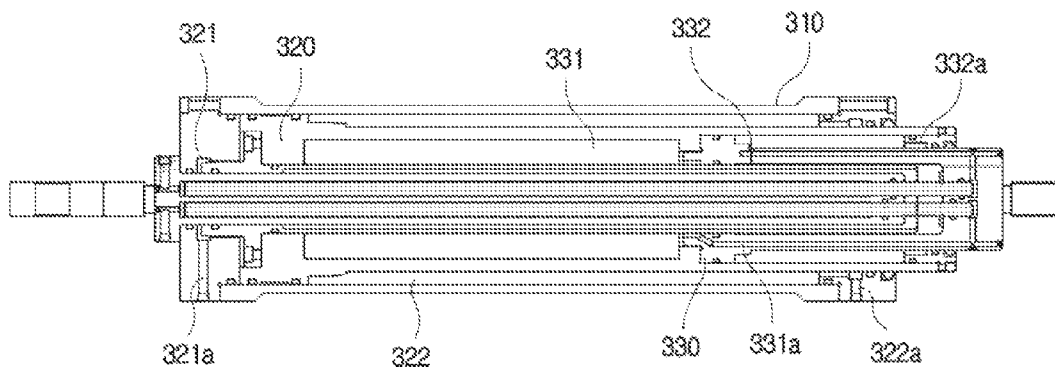

FIG. 4

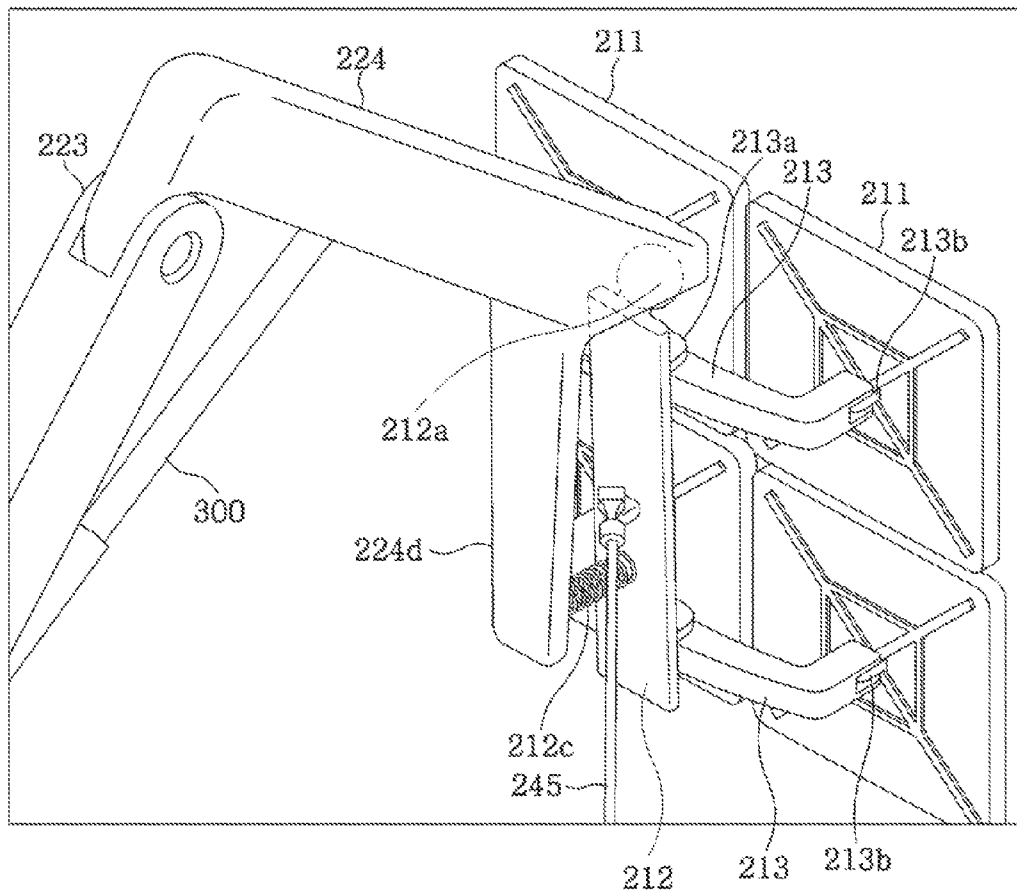

FIG. 5

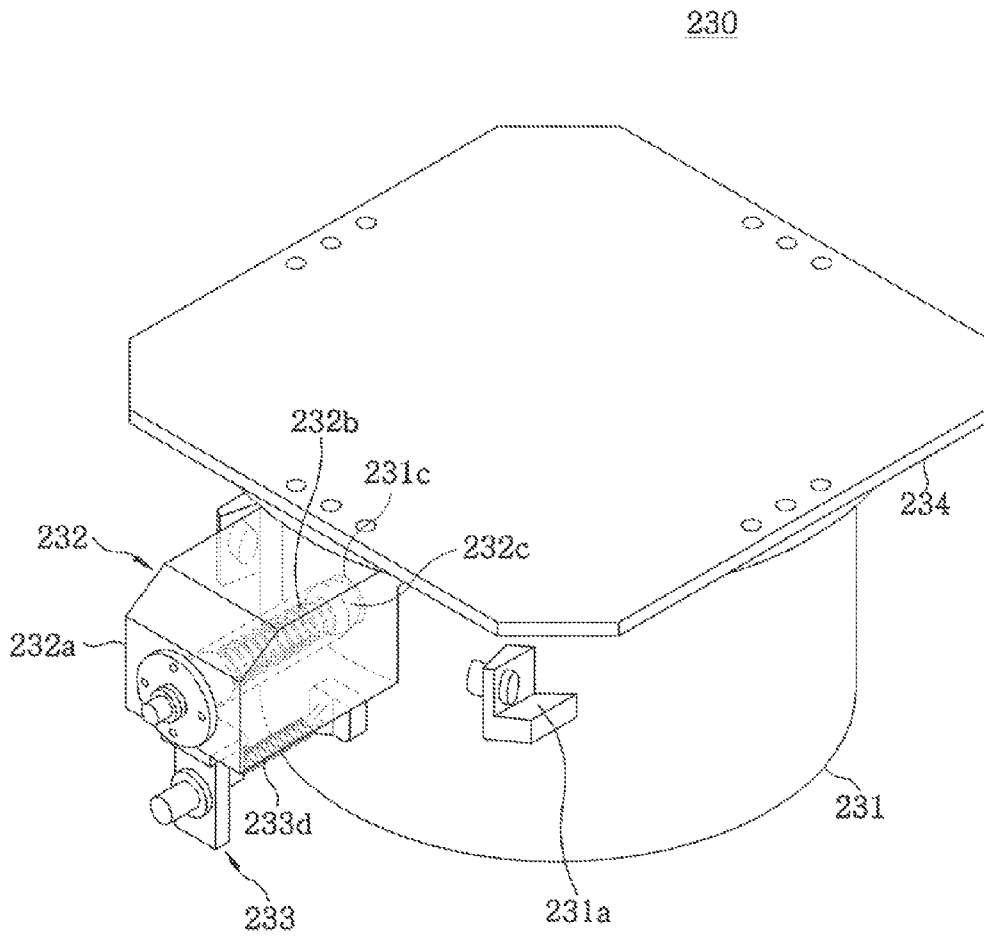

FIG. 6A

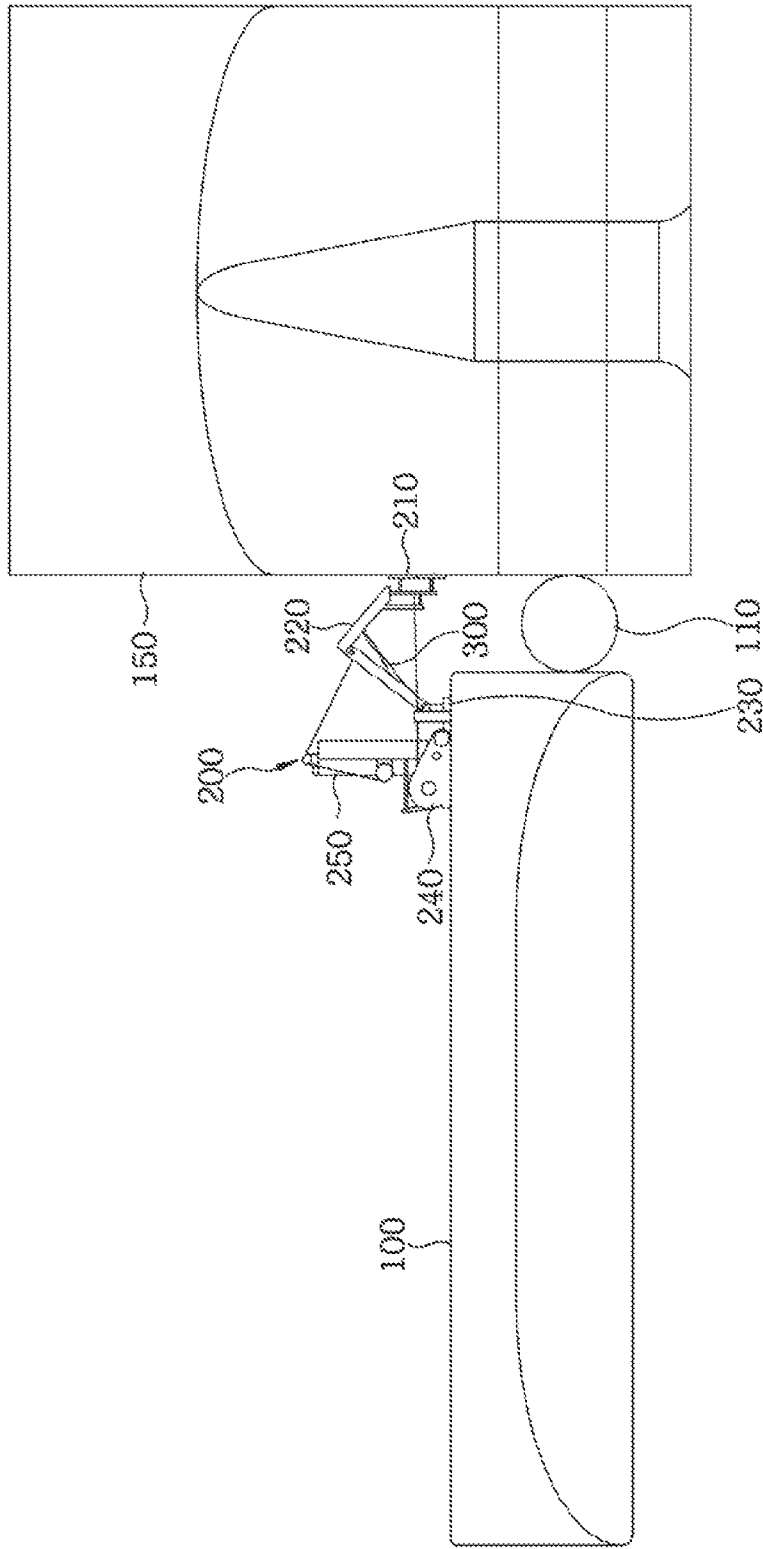

FIG. 6B

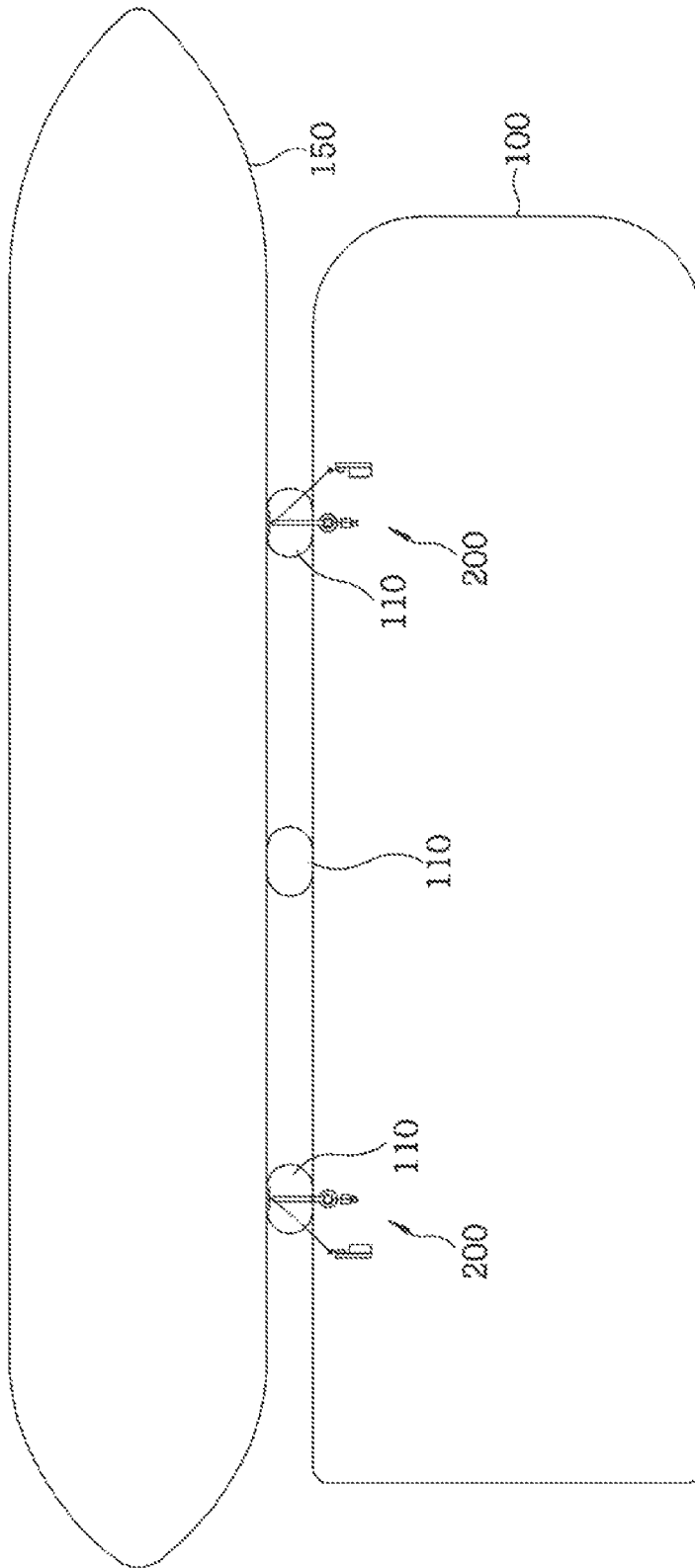
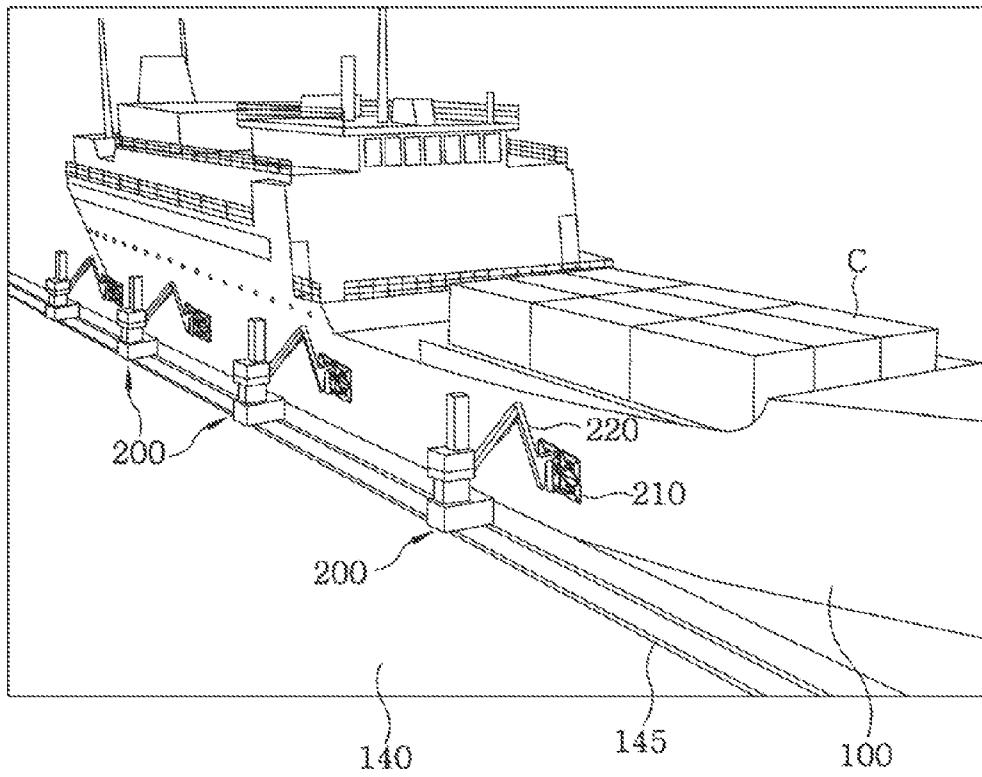

FIG. 7



1

MOORING SYSTEM FOR A VESSEL

FIELD OF THE INVENTION

The present invention relates to a mooring system for a vessel.

BACKGROUND OF THE INVENTION

Recently, in order to improve the efficiency of marine transportation using containers, large vessels have been used in order to improve the cost effectiveness by increasing the cargo amount. In this connection, there is demand for the development of a new system which is capable of loading and unloading cargo on the sea remote from the land, without berthing such large vessels at a quay wall of a harbor which is provided on the land. Thus, research into a mobile harbor allowing a large ship to anchor in the sea away from the land and to handle cargos, rather than making a large ship to come alongside the pier in the harbor, has been under way.

FIGS. 1A and 1B are schematic diagrams illustrating the mobile harbor in accordance with the related research. The mobile harbor **100** which is a floating body may perform a loading and unloading operation by using a crane **20**. FIG. 1A illustrates a loading and unloading operation between the mobile harbor **10** and a large container carrier **30**, and FIG. 1B illustrates a loading and unloading operation between the mobile harbor **10** and a quay wall **40**.

When a mobile harbor is used to load and unload cargos while a large container carrier is anchored in the sea remote from the land, containers loaded and/or to be loaded on the large container carrier need to be distributed to several small, mobile harbors and transported between the large container carrier and a harbor provided on the land. In this case, the number of berthing operations of the mobile harbors inevitably increases.

In general, a vessel includes a windlass for winding an anchor cable or a mooring winch for winding a mooring rope, in order to moor the vessel in a harbor, and the harbor includes a mooring facility for fixing the mooring rope of the vessel. The conventional vessel or harbor is operated by a manual system depending on human power. Such a manual system has a problem in safety accidents and operation efficiency.

Therefore, there is a need for the development of a new system for quickly and stably mooring or docking a vessel such as a mobile harbor or container carrier.

SUMMARY OF THE INVENTION

The present invention provides a mooring system for a vessel capable of minimizing the time and effort required for a mooring operation on vessels, and maintaining a stable mooring state such that cargos can be smoothly loaded and unloaded.

In accordance with an aspect of the present invention, there is provided a mooring system for a vessel, including: an attachment unit configured to be detachably attached to a hull of the vessel; a robot arm including a plurality of arms, the arms being coupled to each other to turn in a vertical direction, the robot arm extending by an arm actuator provided thereto to transfer the attachment unit to an attachment position the hull; a rotation unit connected to the robot arm and allowing the robot arm to turn in a horizontal direction; and a mooring winch for winding a mooring cable to draw the attachment unit.

2

In accordance with another aspect of the present invention, there is provided a floating body including the mooring system.

In accordance with still another aspect of the present invention, there is provided a quay wall including the mooring system

BRIEF DESCRIPTION OF THE DRAWINGS

The objects and features of the present invention will become apparent from the following description of embodiments given in conjunction with the accompanying drawings, in which:

FIG. 1A is a schematic diagram illustrating a loading and unloading operation of a mobile harbor on the sea;

FIG. 1B is a schematic diagram illustrating a loading and unloading operation of the mobile harbor on the land;

FIG. 2A is a schematic view of a mooring system for a vessel in accordance with an embodiment of the present invention, while the mooring system is mooring a vessel;

FIG. 2B is a schematic view of the mooring system for a vessel in accordance with the embodiment of the present invention, while a floating body including the mooring system sails;

FIG. 3A is a conceptual diagram illustrating a multi-stage hydraulic cylinder and hydraulic circuits in accordance with the embodiment of the present invention;

FIG. 3B is a cross-sectional view of the multi-stage hydraulic cylinder in accordance with the embodiment of the present invention;

FIG. 4 is a schematic view of an attachment unit in accordance with the embodiment of the present invention;

FIG. 5 is a schematic view of a rotation unit in accordance with the embodiment of the present invention;

FIG. 6A is a front view conceptual diagrams illustrating a state in which a mobile harbor having the mooring system mounted thereon is berthing at a container carrier;

FIG. 6B is a plan view of the conceptual diagrams of FIG. 6A; and

FIG. 7 is a conceptual diagram illustrating a state in which a mobile harbor is berthing at a quay wall in which the mooring system in accordance with the embodiment of the present invention is disposed.

DETAILED DESCRIPTION OF THE EMBODIMENTS

Hereinafter, embodiments of the present invention will be described in detail with reference to the accompanying drawings. Same reference numeral is given to the same or corresponding element, and a duplicated explanation thereon will be omitted.

FIGS. 2A and 2B are schematic views of a mooring system for a vessel in accordance with an embodiment of the present invention. FIG. 2A is a side view of the mooring system while the mooring system is mooring a vessel, and FIG. 2B is a perspective view of the mooring system while a floating body (or a floating structure) including the mooring system sails.

The mooring system **200** includes an attachment unit **210**, a robot arm **220**, a rotation unit **230**, a mooring winch **240**, and a robot arm winch **250**.

The robot arm **220** includes a plurality of arms which are coupled with hinges to turn in a vertical direction. The robot arm **220** may be extended through extension of an arm actuator to transfer the attachment unit **210** to an attachment position of a hull.

Specifically, the robot arm **220** may include a first arm **223** having an end coupled to the rotation unit **230** provided on an installation surface and a second arm **224** having an end coupled to the other end of the first arm **223** with a hinge **225**. The first arm **223** is coupled to the rotation unit **230** with a hinge **226** to turn in the vertical direction.

The arm actuator may have a hydraulic cylinder **300**. The cylinder **300** is connected between the first and second arms **223** and **224** and extends to transfer the attachment unit **210**. The hydraulic cylinder **300** and the second arm **224** are connected through a spring **224c** to absorb an impact applied to the second arm **224**.

The robot arm **220** has a protrusion portion **224d** which protrudes to be positioned behind the connection member **212** of the attachment unit **210**, and the connection member **212** is connected to the protrusion portion **224d** through a spring **212c** to absorb an impact applied to the attachment unit **210**.

The robot arm **220** of the mooring system is not limited to the 2-arm link structure illustrated in FIGS. **2A** and **2B**, but may be constructed to have a variety of link structures. For example, the robot arm **220** may include one or more additional arms, or may have a 4-arm link structure in which a pair of 2-arm links is formed between the rotation unit **230** to the attachment unit **210**.

FIG. **3A** is a conceptual diagram illustrating a multi-stage hydraulic cylinder and hydraulic circuits in accordance with the embodiment of the present invention, and FIG. **3B** is a cross-sectional view of the multi-stage hydraulic cylinder.

The hydraulic cylinder **300** in accordance with the embodiment of the present invention may include a multi-stage hydraulic cylinder which independently controls the stroke of two or more piston to perform extension and contraction for positioning of the attachment unit **210** and absorption of an impact applied to the attachment unit **210**. One piston rod may freely move to provide room for the vessel which rolls or pitches on the sea, and absorb an impact applied by a vessel, in a state that the hydraulic cylinder **300** is in neutral. On the other hand, another piston rod may stop in a state that the multi-stage hydraulic cylinder **300** is in neutral.

The multi-stage hydraulic cylinder **300** includes a cylinder housing **310** having a space formed therein and an opened upper surface and the first and the second-stage piston rod **320** and **330**. The first-stage piston rod **320** is inserted into an upper surface (right side in FIG. **3A**) of the cylinder housing **310**, divides an internal space of the cylinder housing **310** to form a first and a second chamber **321** and **322** to thereby have, and has a space formed therein and an opened upper surface. The second-stage piston rod **330** is inserted into the upper surface of the first-stage piston rod **320** and divides an internal space of the first-stage piston rod **320** to form a third and a fourth chamber **331** and **332**.

The first to fourth chambers **321**, **322**, **331**, and **332** may include first to fourth openings **321a**, **322a**, **331a**, and **332a**, respectively, which are sealed and with which a fluid communicates to apply an oil pressure. The first-stage and second-stage piston rods **320** and **330** have respective hollow holes **323** and **333** formed therein, and a fluid may communicate with the third and fourth chambers **331** and **332** through flow paths formed in the respective hollow holes. The cylinder housing **310** has an opened lower surface (left side in FIG. **3A**), and a fluid may communicate with the third and fourth openings **331a** and **332a** through the lower surface of the cylinder housing **310**.

An oil pressure applied to the pair of the first and second chambers **321** and **322** and an oil pressure applied to the pair of the third and fourth chambers **331** and **332** may be controlled by a first-stage hydraulic circuit **340** and a second-

stage hydraulic circuit **350**, respectively, which are independently provided. When an oil pressure is applied to the first or the second chamber **321** or **322**, the first-stage piston rod **320** is moved vertically (in the horizontal direction in FIG. **3A**), and the length of the hydraulic cylinder **300** is extended or contracted. When an oil pressure is applied to the third or the fourth chamber **331** or **332**, the second-stage piston rod **330** is moved vertically, and the length of the hydraulic cylinder **300** is extended or contracted. The first-stage hydraulic circuit **340** and the second-stage hydraulic circuit **350** may include check valves **341**, **342**, **351**, and **352** through which a fluid communicates with the first to fourth openings **321a**, **322a**, **331a**, and **332a**, respectively, to apply an oil pressure.

Chambers in any one pair of the pair of the first and second chambers **321** and **322** and the pair of the third and fourth chambers **331** and **332** may communicate with each other when the hydraulic cylinder **300** is in neutral state. On the other hand, the other pair of chambers may be disconnected from an external hydraulic circuit when the hydraulic cylinder **300** is in neutral state. In this embodiment, the pair of the first and second chambers **321** and **322** may communicate with each other such that the first-stage piston rod **320** freely moves in case of neutral state. The pair of the third and fourth chambers **331** and **332** may be disconnected from an external hydraulic circuit to stop the second-stage piston rod **330** in case of neutral state.

The first-stage hydraulic circuit **340** can make the first-stage piston rod **320** freely move. For this operation, the first-stage hydraulic circuit **340** may include an ABT-connected four-direction control valve **344**. The second-stage hydraulic circuit **350** can stop the second-stage piston rod **330**. For this operation, the second-stage hydraulic circuit **350** may include a closed-center four-direction control valve **354**.

In this embodiment, the two-stage cylinder has been described, but may be extended to three stages or more. In the multi-stage cylinder in accordance with the embodiment of the present invention, two or more piston rods may be independently controlled to perform the extension of the cylinder length and the impact absorption at the same time. Therefore, the multi-stage cylinder **300** may have two or more functions through a simple construction.

FIG. **4** is a schematic view of the attachment unit **210** in accordance with the embodiment of the present invention.

The attachment unit **210** is detachably attached to a hull of a vessel to be berthed, such as a container carrier. The attachment unit **210** may include a plurality of suction pads **211** for generating an attachment force by which the attachment unit **210** is attached to the hull. Each of the suction pads **211** may be attached to the hull by vacuum supplied through a vacuum supply line from a vacuum supply unit (not illustrated). For this operation, the suction pad **211** may include a plurality of vacuum holes to which vacuum is supplied. Alternatively, the suction pad **211** may include an electromagnet which is attached to the hull by a magnetic force caused by power supply.

The attachment unit **210** may include a connection member **212** for connecting the suction pad **211** to an end of the robot arm **220**. The robot arm **220** and the connection member **212** may be coupled by a ball joint **212a** so as to rotate about each other.

The suction pads **211** may be coupled to auxiliary connection members **213** by hinges **213b**, respectively. In this case, the suction pads **211** may be arranged in line or in a two-dimensional manner with respect to the connection member **212**. Each of the auxiliary connection members **213** has an end coupled to the connection member **212** by the ball joint

213a. The suction pads **211** may be moved with a multi degree of freedom by the ball joints **212a** and **213a** and the hinges **213b**. Therefore, the suction pads **211** may change the posture in correspondence to various shapes of hulls. Alternatively, the ball joints and hinges **212a**, **213a** and **213b** may be substituted with joints of different type.

FIG. 5 is a schematic view of the rotation unit **230** in accordance with the embodiment of the present invention.

The rotation unit **230** is connected to the robot arm **220** to rotate the robot arm **220** in a horizontal direction (e.g., in a left and right direction) within a predetermined angle range based on the axis perpendicular to the installation surface. When the floating body having the mooring system **200** installed therein moves in the longitudinal, direction thereof, a rotational force is applied.

The rotation unit **230** includes a rotation member **234**, a rotation adjustment part **232**, a fixed shaft **231**, and a restoration part **233**. The rotation member **234** is connected to the robot arm **220** to rotate in the horizontal direction together with the robot arm **220**. The rotation adjustment part **232** allows the rotation member **234** to rotate from an initial position, when a predetermined load or a load more than that is applied. The fixed shaft **231** includes stopper for limiting the rotation member **234** within a predetermined angle range, for example, 15 degrees and is fixed to the installation surface. The restoration part **233** restores the rotated rotation member **234** to the initial position.

The rotation adjustment part **232** includes a case **232a** coupled to be fixed to the rotation member **234**, and the case **232a** is rotated together with the rotation member **234**. The rotation of the case **232a** is limited by the stopper **231a**. A ball **232c** is provided inside the case **232a**, and has portion inserted into a hole **231c** formed in the fixed shaft **231**. When a rotational force of a predetermined load or more is applied, the ball **232c** may be moved out of the hole **231c**. A spring **232b** applies a compressive force to the ball **232c** such that the compressive force is directed toward the hole **231c**. When a load less than the predetermined load is applied, the spring **232b** stops the ball **232c**.

The restoration part **233** includes a spring **233d** having both ends coupled to the rotation adjustment part **232** and the fixed shaft **231**, respectively. When the rotation member **234** is rotated, the spring **233d** is lengthened to restore the rotation member **234**.

Referring to FIGS. 2A and 2B, the mooring winch **240** winds the mooring cable **245** to draw the hull attached to the attachment unit **210** toward the installation surface. The mooring winch **240** serves to suppress the vessel from moving away from the mooring system **200** when the attachment unit **210** is attached to the hull. Although not illustrated, the mooring winch **240** includes a variety of sensors and actuators which control a mooring force to be automatically and constantly maintained. The mooring operation may be stably and automatically performed in correspondence to a drift, winds, waves, tides, and the like.

When the attachment unit **210** is attached to the hull, the driving power of the robot arm **220** may be turned off. Then, the mooring winch **240** may cover all or most of the load generated by the mooring of the vessel such that the load, is not applied to the robot arm **220**. The mooring winch **240** may free the robot arm **220** from the load. The hydraulic cylinder **300** may be freely extended and contracted when the mooring winch serves to suppress the vessel. Therefore the physical fatigue of the robot arm **220** may be prevented, and the structure may be simplified.

The mooring cable **245** has an end connected to the attachment unit **210** to draw the attachment unit **210**. For example,

the mooring cable **245** may be directly connected so the connection member **212** or connected through a separate member. Alternatively, the mooring cable **245** may be connected to an end of the robot arm **220**.

The robot arm winch **250** may wind the robot arm cable **255** to draw the robot arm **220**. Similar to the mooring winch **240**, the robot arm winch **250** may cover a load generated when the attachment unit **210** is attached to the hull, thereby preventing the physical fatigue of the structure.

Meanwhile, although not illustrated, the mooring system **200** in accordance with the embodiment of the present invention may include a variety of actuators for driving the winch, the hinges, the ball joints, and the cylinder.

In the mooring system **200**, a position and posture of the attachment unit **210** may be adjusted in correspondence to a size or a shape of a vessel to be berthed, thereby making it possible to berth the vessel efficiently. Furthermore, the docking impact is absorbed by the multi-stage cylinder **300** and the elasticity of the springs **224c** and **212c**, and the distance between vessels is constantly maintained to stably berth or anchor the vessels. Furthermore, the mooring system **200** may minimize the use of human power such that the mooring operation automatically performed, thereby reducing the danger of safety accident and increasing the efficiency.

FIGS. 6A and 6B are conceptual diagrams illustrating a state in which a mobile harbor having the mooring system mounted thereon is berthing at a container carrier. FIG. 6A is a front view, and FIG. 6B is a plan view.

A plurality of the mooring systems **200** may be disposed on a side surface of a floating body such as a mobile harbor. The mobile harbor **100** may include a vessel which may move by using its own power or a floating body moored on the sea. The mobile harbor **100** may transfer containers between the container carrier **150** and a harbor on the land, and temporarily load containers in place of the harbor on the land, while floating on the sea.

The mobile harbor **100** may include a platform having a space in which a container is loaded, a loading device (e.g. a crane) for handling a container, a location determining device for acquiring information regarding the location of the platform, and a balancing device for adjusting the platform such that the platform can be maintained in a vertical location correspondingly to a change in she weight based on the loading and unloading of the container.

The mobile harbor **100** in accordance with the embodiment of the present invention may further include a fender **110** installed between the mobile harbor **100** and the hull of a vessel, such as the container carrier **150**. Therefore, when the mooring cable **245** is wound, the fender **110** prevents the hull from colliding with the mobile harbor **100**, and simultaneously pushes the hull to maintain the tension of the mooring cable **245**. Therefore, even when the sea condition is not stable, for example, even when the waves are high, the mooring operation for the vessel can be performed stably.

The fender **110** may be installed on the mobile harbor **100**, the hull of the container carrier **150**, or another structure. The fender **110** may have a variety of installation structures. For example, the fender **110** may be installed to float on the surface of the sea or fixed to be positioned at a predetermined level. The fender **110** may be formed of a structure capable of enduring a strong external force and frictional force, while absorbing an impact.

FIG. 7 is a conceptual diagram illustrating a state in which a mobile harbor is berthing at a quay wall in which the mooring system in accordance with the embodiment of the present invention is disposed.

The mooring system **200** may be disposed at a quay wall **140** or a quay on the land and used when a vessel is berthed or moored at the quay wall on the land. The mooring system **200** may moor the mobile harbor **100** at a proper position while moving along a rail **145** formed on the quay wall **140**. In addition, another vessel such as a container carrier or a floating body may be moored at the quay wall **140** where the mooring system in accordance with the embodiment of the present invention is installed.

Hereinafter, referring to FIGS. **6A** and **6B**, a mooring method in a case in which the mooring system in accordance with the embodiment of the present invention is installed in a mobile harbor will be described.

The mooring method may include a step of transferring the attachment unit **210** to the hull by using the robot arm **220**, a step of attaching the attachment unit **210** to the hull, a step of putting the hydraulic cylinder **300** of the robot arm **220** into neutral, and a step of winding the mooring cable **245**.

At the step of transferring the attachment **210** to the hull by using the robot arm **200**, the mobile harbor **100** is approximated to the container carrier **150** to be berthed, and an optimal attachment position is selected. The attachment unit **210** may be transferred to the position, by the movement of the robot arm **220** and the posture change of the attachment unit **210**. At this time, the movement of the robot arm **220** may be performed by the extension of the hydraulic cylinder **300** and the suction pads **211** are rotated by the ball joints **212a** and **213a** and hinges **213b**.

At the step of attaching the attachment unit **210** to the hull, the attachment unit **210** may be attached to the hull by the supply of vacuum or a magnetic force.

At the step of winding the mooring cable **215**, the mooring cable **245** is wound by the mooring winch **240** to draw the attachment unit **210**, in order to cover a load caused by docking or mooring the vessel. At this time, the hydraulic cylinder **300** of the robot arm **220** is put into neutral. And further the power (or actuators) of the hinges **213b** or the ball joints **212a** and **213a** may be turned off, in order to free the robot arm **220** from the load.

Before the mooring cable **245** is wound, the fender **110** may be installed between the mobile harbor **100** having the robot arm **220** installed thereon and the hull of the container carrier **150**.

In accordance with the embodiment of the present invention, the mooring system may minimize the time and effort required for a mooring operation, and may maintain a stable mooring state therebetween such that cargo is smoothly loaded and unloaded.

The mobile harbor in accordance with the embodiment of the present invention performs a loading and unloading operation for a large container carrier on the sea. Therefore, the cargo transportation of a large container carrier, which needs to be performed in deep water, may be efficiently processed, whereby it will contribute to strengthening the harbor system competitiveness.

While the invention has been shown and described with respect to the preferred embodiments, it will be understood by those skilled in the art that various changes and modifications may be made without departing from the scope of the invention as defined in the following claims.

What is claimed is:

1. A mooring system for a vessel, comprising:
 - an attachment unit configured to be detachably attached to a hull of the vessel;
 - a robot arm including a plurality of arms, the arms being coupled to each other to turn in a vertical direction, the

robot arm extending by an arm actuator provided thereto to transfer the attachment unit to an attachment position of the hull;

a rotation unit connected to the robot arm and allowing the robot arm to turn in a horizontal direction; and
a mooring winch for winding a mooring cable to draw the attachment unit,

wherein the attachment unit includes a plurality of suction pads configured to generate a suction force by which the attachment unit is attached to the hull, and

wherein the rotation unit includes:

a rotation member connected to the robot arm to rotate in the horizontal direction together with the robot arm, and a rotation thereof being limited within an angle range;

a rotation adjustment part allowing the rotation member to rotate from an initial position when a predetermined load or greater is applied thereto; and

a restoration part for restoring the rotation member rotated by the rotation member to the initial position.

2. The mooring system of claim 1, wherein the robot arm includes a first arm coupled to the rotation unit and a second arm coupled to the first arm and the attachment unit; and the arm actuator has a hydraulic cylinder connected to the first arm and the second arm and serving to absorb an impact applied to the second arm.

3. The mooring system of claim 2, wherein the hydraulic cylinder is connected to the second arm through a spring to absorb the impact applied to the second arm.

4. The mooring system of claim 2, wherein the second arm has a protrusion portion disposed behind the attachment unit; and

the attachment unit is connected to the protrusion portion through a spring to absorb an impact applied to the attachment unit.

5. The mooring system of claim 1, wherein the attachment unit includes a connection member for connecting the suction pads to the robot arm; and

the robot arm and the connection member are coupled to each other by a ball joint.

6. The mooring system of claim 5, wherein the suction pads are arranged in a two-dimensional manner; and each of the suction pads is coupled to the connection member through a ball joint.

7. The mooring system of claim 1, wherein the rotation adjustment part has:

a case which is rotated together with the rotation member; a ball provided in the case and having a portion inserted into a fixed hole, the ball being moved out of the hole when the predetermined load or greater is applied; and

a spring provided in the case and applying a compressive force to the ball toward the hole.

8. The mooring system of claim 1, wherein the mooring winch serves to suppress the vessel from moving away from the mooring system when the attachment unit is attached to the hull.

9. The mooring system of claim 1, further comprising a robot arm winch for winding a robot arm cable to draw the robot arm.

10. The mooring system of claim 1, wherein the robot arm includes a first arm coupled to the rotation unit and a second arm coupled to the first arm and the attachment unit;

the arm actuator has a hydraulic cylinder connected to the first arm and the second arm and serving to absorb an impact applied to the second arm,

the attachment unit includes a plurality of suction pads for generating an suction force by which the attachment unit is attached to the hull;

the mooring winch serves to suppress the vessel from moving away from the mooring system when the attachment unit is attached to the hull.

11. A floating body comprising the mooring system of claim 1.

5

12. The floating body of claim 11, further comprising a fender provided between a side surface thereof and the hull.

13. A quay wall comprising the mooring system of claim 1.

14. The quay wall of claim 13, further comprising a rail allowing the mooring system to move thereon.

10

* * * * *